

Aviation Fabricators
805 North Fourth Street
Clinton MO 64735

Document No: AF-438
Revision: (E)
Date: April 24, 2018

INSTRUCTIONS FOR CONTINUED AIRWORTHINESS

For

1, 2, & 3 Place Side Facing Divan Installations

Document No.: AF-438

Revision "E"

Revision Date: 04/24/18

Applicable to:

Beechcraft 65, A65, A65-8200, 65-80, 65-A80, 65-A80-8800, 65-B80, 65-88, 65-90, 65-A90, 65-A90-1, 65-A90-2, 65-A90-3, 65-A90-4, B90, C90, C90A, C90GT, E90, F90, 99, 99A, A99, A99A, B99, C99, 100, A100, A100A, A100C, B100, 200, 200C, 200CT, 200T, A200, A200C, A200CT, B200, B200C, B200CT, B200T, B200GT, B200CGT, 300, B300, B300C, 300LW Series Aircraft

Modified by FAA STC SA4157SW

The information in the Instruction for Continued Airworthiness is FAA accepted material and complies with 14 CFR 23.1529, Instructions for Continued Airworthiness. It supersedes or adds to that provided in the Maintenance Manual for the Beechcraft 65, 90, 100, 200, and 300 Series Aircraft, only where covered in the items contained herein. For limitations and procedures not contained in the Supplement, consult the Component Maintenance Manual, or other approved airplane data.

REVISION PAGE

Document Title: Instructions for Continued Airworthiness

Prepared By: Todd Pogue

Reviewed By: Brian C. Adamson

Updates to the ICA will be made by Aviation Fabricators Inc. Updates will be listed in the log of revisions and the effective pages will be listed below.

Log of Revisions				
REV. NO.	EFFECTED PAGE(S)	DESCRIPTION	DATE	APPROVED BY
IR	All	Initial Release	04-14-08	G.R. Lowe III
A	3	Added Maintenance Manual Schedule	06-27-08	G.R. Lowe III
B	All	Updated entire document to comply with 14 CRF 23.1529	03-23-10	G.R. Lowe III
C	All	Added part #'s 32-0394 & 32-0395	05-31-11	JeffreyR. Lowe
D	All	*Updated Section 10 to latest format, p18 *Added Section 11 Troubleshooting, p18	12-28-12	JeffreyR. Lowe
E	All	*Added P/N 32-0406K for 1 Place Storage Divan w/ Ice Tank, p5 *Added all (K-1) P/N's for all divan configurations w/ 4 point harness, p5 *Added W&B info for P/N 32-0502K for 4 point harness, p15 *Added W&B info for drawer w/ ice tank, p15	04-24-18	JeffreyR. Lowe

Per the requirement of Appendix G of 14 CFR Part 23 paragraph G23.1 (c), the changes made to the ICA by the applicant will be distributed via mail by means of paper copy.

TABLE OF CONTENTS

INSTRUCTIONS FOR CONTINUED AIRWORTHINESS	1
REVISION PAGE	2
TABLE OF CONTENTS	3
1.0 INTRODUCTION	5
2.0 INSPECTION REQUIREMENTS AND OVERHAUL SCHEDULE	12
3.0 DIMENSION AND ACCESS	14
4.0 LIFTING AND SHORING	14
5.0 LEVELING AND WEIGHING	14
6.0 TOWING AND TAXIING	14
7.0 PARKING AND MOORING	15
8.0 PLACARDS AND MARKINGS	15
9.0 SERVICE INFORMATION	16
10.0 AIRWORTHINESS LIMITATIONS	18
11.0 TROUBLESHOOTING	18

ABBREVIATIONS AND DEFINITIONS

Abbreviations	Definitions
AML	FAA Approved Model List (AML)
Detailed Inspection (DET)	An intensive examination of a specific item, installation or assembly to detect damage, failure or irregularity. Available lighting is normally supplemented with a direct source of good lighting at an intensity deemed appropriate. Inspection aids such as mirrors, magnifying lenses, etc. may be necessary. Surface cleaning and elaborate access procedures may be required.
FAA	Federal Aviation Administration
FAA MIDO	FAA Manufacturing Inspection District Office
General Visual Inspection (GVI)	A visual examination of an interior or exterior area, installation or assembly to detect obvious damage, failure or irregularity. This level of inspection is made from within touching distance unless otherwise specified. A mirror may be necessary to enhance visual access to all exposed surfaces in the inspection area. This level of inspection is made under normally available lighting conditions such as daylight, hangar lighting, flashlight or droplight and may require removal or opening of access panels or doors. Stands, ladders or platforms may be required to gain proximity to the area being checked.
ICA	Instructions for Continued Airworthiness
Special Detailed Inspection (SDI)	An intensive examination of a specific item, installation , or assembly to detect damage, failure or irregularity. The examination is likely to make extensive use of specialized Inspection Techniques and/or equipment. Intricate cleaning and substantial access or disassembly procedure may be required.
STC	Supplemental Type Certificate

1.0 INTRODUCTION

The purpose of this Maintenance Manual Supplement and Instructions for Continued Airworthiness (ICA) is to provide the maintenance technician with the information necessary to ensure the continued airworthiness of the Aviation Fabricators 1, 2, & 3 place divan installations, per installation numbers:

32-0151K, 32-0151K-1, 32-0152K, 32-0152K-1, 32-0153K, 32-0153K-1,
32-0317K, 32-0317K-1, 32-0318K, 32-0319K, 32-0394K, 32-0394K-1,
32-0395K, 32-0395K-1, 32-0406K, & 32-0406K-1

when installed in accordance with Aviation Fabricators design data included on STC Drawing List AF-291 and per Supplement Type Certificate (STC) SA4157SW.

Modifications to an aircraft obligates the operator to include the maintenance information provided by this document into the operators aircraft Maintenance Manual and operator's aircraft scheduled maintenance program. This document defines supplementary maintenance operations and frequencies recommended by Aviation Fabricators Inc., to ensure the aircraft's airworthiness.

The information contained herein addresses the requirements specified in 14 CFR 23.1529, Instructions for Continued Airworthiness and supplements the basic Airplane Maintenance Manual only in those areas listed as pertains to the installation of the side facing divans, as installed per the Aviation Fabricator STC Drawing List AF-291. For limitations and procedures not contained in this supplement, consult the basic Airplane Maintenance Manual.

DATA

All information to support the continued airworthiness of this modification is contained in:

STC SA4157SW.
STC Drawing List: AF-291.

Installation: STC Drawing List: AF-291:
Drawing D-10403 for P/N's 32-0151K, 32-0151K-1, 32-0152K,
32-0152K-1, 32-0153K, and 32-0153K-1
Drawing D-10404 for P/N's 32-0318K, 32-0319K, 32-0394K,
32-0394K-1, 32-0395K, and 32-0395K-1
Drawing D-10422 for P/N's 32-0317K, 32-0317K-1, 32-0406K, and
32-0406K-1

Reference: STC drawing list: AF-203 (per STC SA00622WI):
Drawing D-10124 for P/N 32-0181K
Drawing D-10830 for P/N 32-0502K

Parts: Refer to respective drawings as listed on STC Drawing List AF-291.

The divan is a self contained complete assembly that mounts anywhere in the cabin to the existing seat track, using standard fittings, in accordance with floor plans approved per the airplane flight manual or a separate installer obtained FAA field approval.

Design Change Control

All data and changes to the parts and assemblies will be tracked per STC Drawing List AF-291 Rev G or later approved revision.

Applicable Aircraft

Beechcraft 65, A65, A65-8200, 65-80, 65-A80, 65-A80-8800, 65-B80, 65-88, 65-90, 65-A90, 65-A90-1, 65-A90-2, 65-A90-3, 65-A90-4, B90, C90, C90A, C90GT, E90, F90, 99, 99A, A99, A99A, B99, C99, 100, A100, A100A, A100C, B100, 200, 200C, 200CT, 200T, A200, A200C, A200CT, B200, B200C, B200CT, B200T, B200GT, B200CGT, 300, B300, B300C, 300LW Series Aircraft

1, 2, & 3 Place Divans
2 Place Divan Shown
Top not shown for clarity

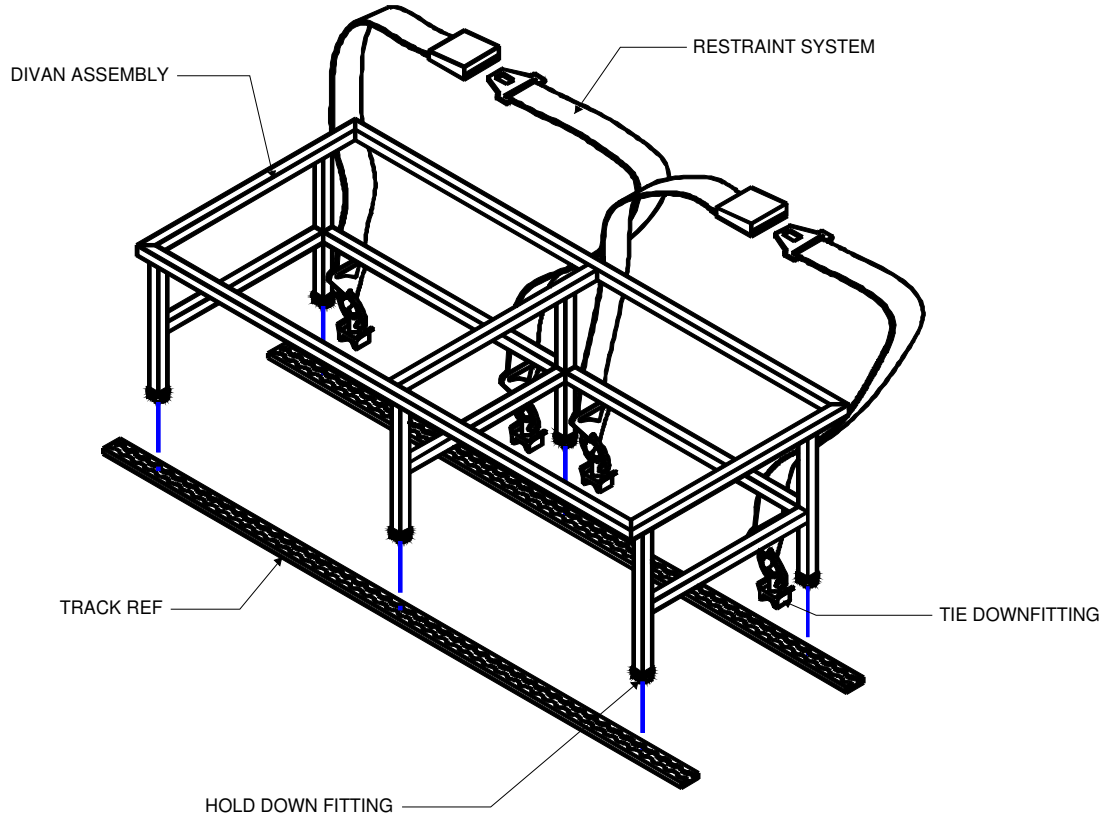

Figure 1.0A

Foot Installation

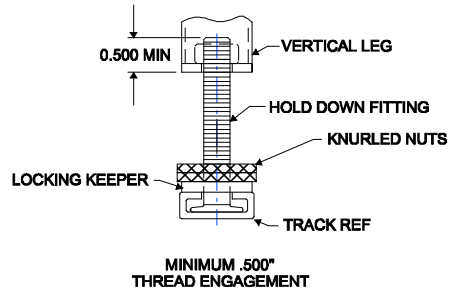

Figure 1.0B

Seat Belt Attachment

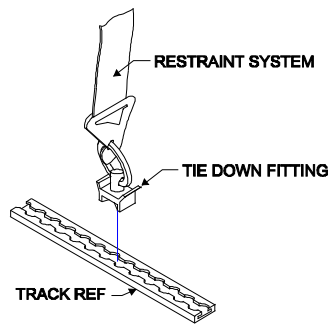

Figure 1.0C

Shoulder Harness Kit

P/N 32-0181K shown, P/N 32-0502K 4 point harness kit not shown, gusset installation is the same

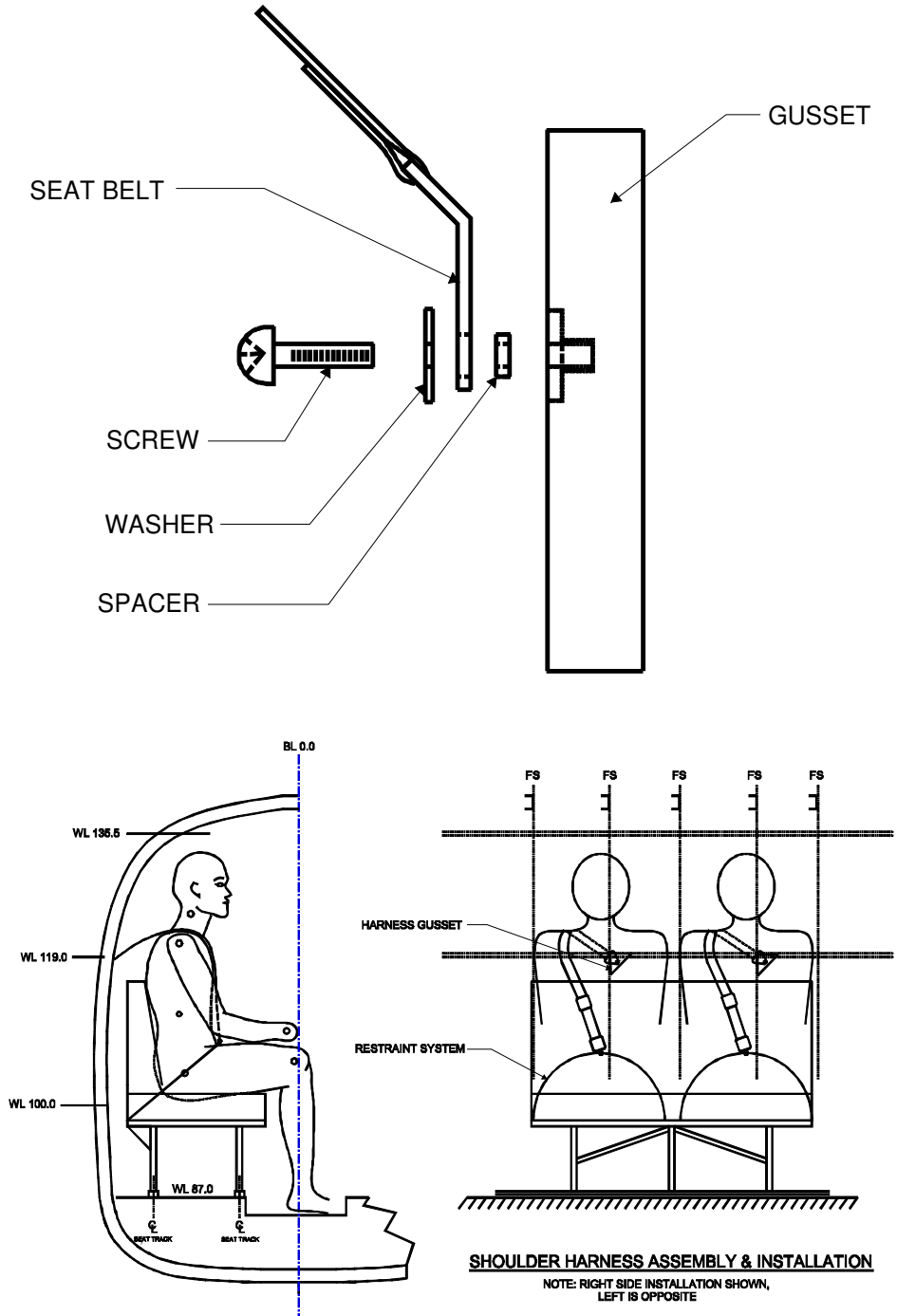

Figure 1.0D

Drawers

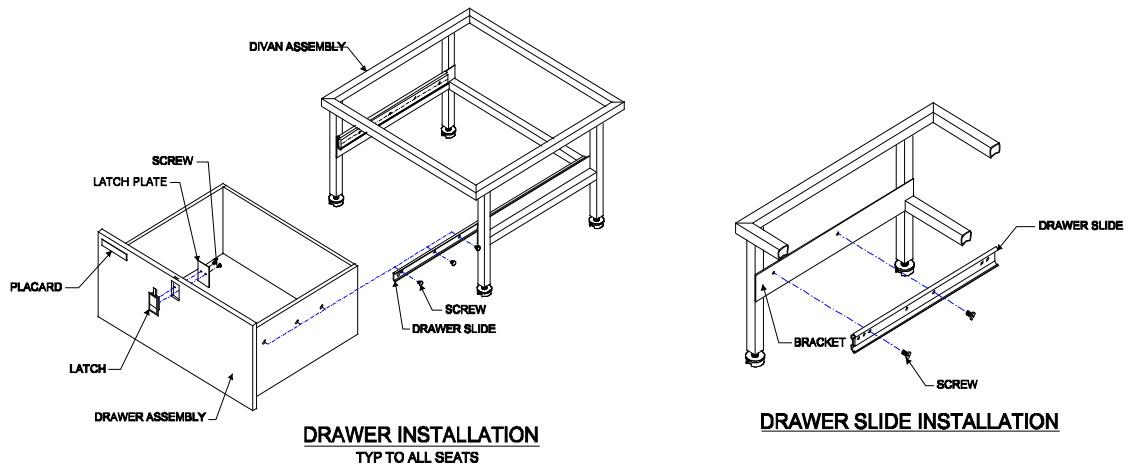

Figure 1.0E

Close-out Panel Assembly

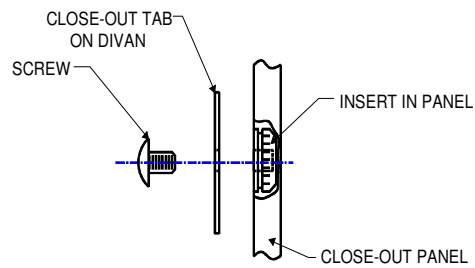

Figure 1.0F

Cushions

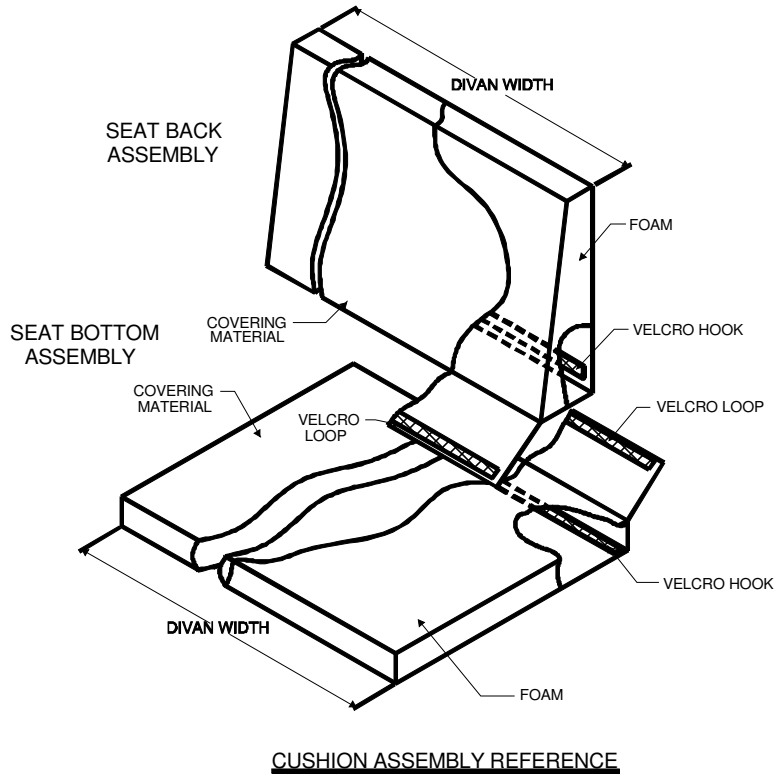

Figure 1.0G

Fwd Bulkhead Cushion

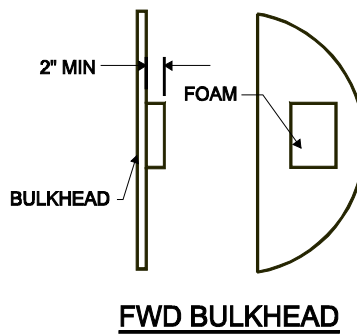

Figure 1.0H

2.0 INSPECTION REQUIREMENTS AND OVERHAUL SCHEDULE

1. To comply with 14 CFR 23.1529, continue the new divan and restraint system on the same inspection and maintenance schedule used per the applicable Hawker Beechcraft Maintenance Manual for seats.
 - a. The new divan installation requires no service other than inspection at normal Phase 4 inspection schedule of 800 hours or 24 months whichever occurs first.
 - b. The safety belts require no service other than inspection at normal inspection interval of 200 hours or annually.
 - c. Perform a detailed visual inspection of each bottom and back cushion and cover to detect apparent or obvious defects, deterioration in the form of wear, tears, rips, punctures or irregularities that cause the cushion assembly to become worn or distorted. Replace the cushion assembly if this cover does not fit properly or the cushion develops a “lumpy” or irregular feel.
 - d. Perform a detailed visual inspection of each divan frame assembly including weld joints, diaphragm, fasteners and anchors, track fittings, and restraint systems to detect apparent or obvious defects, corrosion, cracks, large deformations (permanent deformation in frame tubes more than $\frac{1}{4}$ the overall thickness of the tube diameter), irregularities that cause the frame assembly and/or anchor/fitting to become distorted and not fit into the intended seat track/anchor locations. If deformities are found the divan frame assembly must be removed from the aircraft and returned to Aviation Fabricators for repair or replacement.

2. Inspection Time Limit for 1, 2, or 3 Place Side Facing Divan Assembly Installations:

800 hour inspection or 24 months for the divan assembly
200 hour inspection or annually for the restraint systems

Task Code			Schedule	Date	Mech	Insp
AFI-100	a.	Inspect for damage to upholstery.				
AFI-101	b.	Inspect safety belts for wear, cuts, fraying, damage, and deterioration.				
AFI-102	c.	Inspect safety belt attachment fittings for wear and damage				
AFI-103	d.	Inspect foot fittings for damage, security, and function.				
AFI-104	e.	Inspect seat frame for damage, and corrosion.				
AFI-105	f.	Inspect overall seat for fit and function.				

A. The new divan and restraint system on the same inspection and maintenance schedule used per the applicable Hawker Beechcraft Maintenance Manual for seats.

3.0 DIMENSION AND ACCESS

The installation of the divan does not change the dimensions of the aircraft or alter the access to any existing aircraft system.

4.0 LIFTING AND SHORING

No change.

5.0 LEVELING AND WEIGHING

Due to variable divan options and weights it is the responsibility of the installer to determine the exact final divan weight and location when installing and removing the divan. For reference, the typical divan frame assembly and sub part weights are listed as follows:

1 Place Divan	= 10 lbs
2 Place Divan	= 15 lbs
3 Place Divan	= 20 lbs
32-0181K Shoulder Harness Kit	= 1.5 lbs per seat place
32-0502K 4 Point Harness Kit	= 2.5 lbs per seat place
Drawer Assembly	= 7 lbs each
Drawer Assembly w/ Ice Tank (for P/N 32-0406K)	= 10.5 lbs
Close-out Panel	1 plc = 2.5 lbs
	2 plc = 3.5 lbs
	3 plc = 6 lbs
Maximum Allowable	1 plc = 30 lbs
Divan Weight w/ Seat	2 plc = 50 lbs
Bottom Cushion	3 plc = 75 lbs

6.0 TOWING AND TAXIING

No change.

7.0 PARKING AND MOORING

No change.

8.0 PLACARDS AND MARKINGS

Up to 3 placards are required in conjunction with this modification:

1. If optional close out panels are installed, placard part number 15-0060 must be installed on the top outside of the close-out panel door so that it is visible when the door is closed.



Figure 8.0A

2. A placard stating "to install harness over seat occupant's fwd shoulder" is sewn on to restraint system part numbers 3093-1-051-2396 and should be legible and easily viewed by the seat occupant.



Figure 8.0B

1. If optional drawers are installed, placard part number 17-0370-09 must be installed at the top of the face of the drawer where visible when open or closed.



Figure 8.0C

9.0 SERVICE INFORMATION

Typical Divan Service Instructions:

A. Upholstery Cleaning:

Divan Service Instructions

1. Remove seat back and seat bottom cushion assemblies from sidewall and divan top.
2. If possible dry clean fabric cushions.
3. If dry cleaning is not possible clean fabric with Armour All fabric cleaner or equivalent.
4. Clean leather with Armour All leather cleaner or equivalent.
5. Clean drawer finish using Armour All multi-purpose cleaner or equivalent.
6. Clean and inspect restraint system for damage, fraying, cuts or seam deterioration.
7. Inspect all attachment fittings and replace if necessary.
8. Inspect overall seat for fit and function.

Typical Divan Maintenance Instructions:

Divan Assembly

The divans are self contained complete assemblies that mount to the existing aircraft cabin seat track using standard fittings in accordance with floor plans approved per the airplane flight manual or a separate installer obtained FAA field approval. Refer to Figure 1.0A.

Divan Installation:

The installation of the divan requires (1) setting the divan into the correct location, (2) sliding the divan forward or aft on the track to allow the hold down fitting keeper to lock in place and (3) tightening provided hold down fitting knurled nuts on to the existing seat track on the floor and the outboard sidewall.

Divan Removal:

Removal of the divan assembly requires (1) loosening the attaching hold down fitting hardware, (2) sliding the divan forward or aft to remove the hold down fitting keeper from locking into the seat track, and (3) lifting the divan from its previous location.

Closeout Panels

Underseat close-out panel removal is accomplished by removing screws from under the divan that are attached to inserts in back of panel and attached through tabs on divan frame. Ref. Figure 1.0D

Cushions

Seat back and seat bottom cushion assemblies are removed by simply pulling the cushion inboard away from the Velcro on the sidewall or up away from the Velcro on the pan of the divan assembly, respectively. The seat bottom and seat back cushions should weigh no more than 10 lbs each. All covering and upholstery materials must comply with 14 CFR 23.853 as stated on the installation instructions, D-10403, D-10404, or D-10422. Refer to Figure 1.0E for Cushion Assembly Reference.

Forward Bulkhead Pad

Per the installation instructions, D-10403, D-10404, or D-10422, of the divan assembly, if the divan is installed next to a forward bulkhead, the bulkhead must be properly padded to comply with 14 CFR 23.785. Figure 1.0F

Oxygen Dispensing Unit Availability

Per the installation instructions, D-10403, D-10404, or D-10422, of the divan assemblies, the divan installation must comply with 14 CFR 23.1441. Each dispensing unit must be capable of being readily available to be placed into position on the face of the seat occupant.

B. RECOMMENDED OVERHAUL PERIODS

No additional overhaul time limitations.

10.0 AIRWORTHINESS LIMITATIONS

The Airworthiness Limitations section is FAA approved and specifies maintenance required under Sec. 43.16 and 91.403 of the Federal Aviation Regulations unless an alternative program has been FAA approved.

There are no Airworthiness Limitations to the aircraft with the addition of the 1, 2, or 3 place side facing divans installed by this STC.

11.0 TROUBLESHOOTING

Refer to the existing Aircraft Maintenance Manual for troubleshooting the 1, 2, or 3 place divan installations that is required beyond the information found on the installation drawings D-10403, D-10404, or D-10422.

For replacement parts or repair of damage parts contact Aviation Fabricators at (660) 885-8317.

Troubleshooting this installation should only be accomplished by FAA approved repair stations with the appropriate ratings or appropriately rated operator/individuals, with required test equipment and service data.